

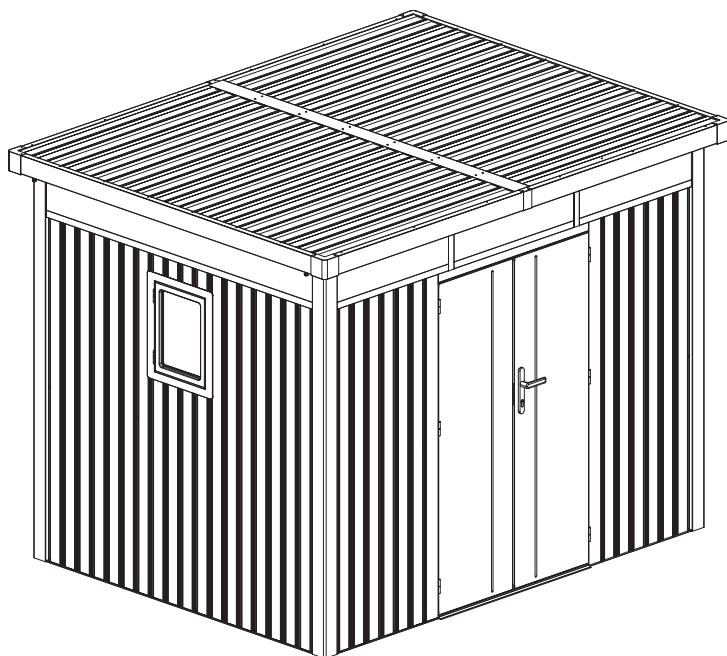

Manual

Garden house G21

Atlanta 676



EN DE CZ SK HU PL HR SLO

۱۲۷

EN

Thank you for purchasing our product.

Before using this unit, please read this manual.

Assembly instructions:

Prior to the assembly please read all instructions and information carefully. The garden house has to be anchored to its base in order to prevent damage. The base is not included in the delivery and it has to be built separately.

Check whether you have all parts which are necessary for the assembly.

Please mind your own safety.

1. 2-3 persons are required for the assembly of this garden house.
2. Use protective clothing and gloves as some parts might be sharp.
3. During the assembly no children or pets should be present in the working area.
4. Do not stand on the roof with all your weight.

Care and maintenance:

1. Clean the house using cloth and water
2. Keep the rails of the sliding door clean and free of any objects that might restrain the door's fluent movement.
3. In case of snowfall remove the snow from the roof regularly.
4. The house is not designed for living but only for storage purposes.

The English version of the manual is an exact translation of the original manufacturer's instructions.

Images used in this manual are for illustrational purposes only and may differ from the actual product.

DE

Vielen Dank für den Kauf unseres Produktes.

Bevor Sie dieses Gerät verwenden, lesen Sie diese Anleitung.

Montageanleitung:

Vor der Montage lesen Sie bitte alle Anweisungen und Angaben vorsichtig. Das Gartenhaus muss auf dem Fundament verankert sein um eine Beschädigung zu verhindern. Das Fundament ist nicht im Lieferumfang enthalten und muss separat angelegt werden.

Überprüfen Sie, ob alle Teile, die für die Montage notwendig sind, vorhanden sind.

Bitte beachten Sie zu Ihrer eigenen Sicherheit.

1. Für die Montage dieses Gartenhauses sind 2-3 Personen erforderlich.
2. Tragen Sie Schutzkleidung und Arbeitshandschuhe, da einige Teile scharfe Kanten haben können.
3. Während des Zusammenbaus sollten sich keine Kinder oder Tiere im Arbeitsbereich aufhalten.
4. Sie sollten sich nicht mit ihrem vollen Gewicht auf das Dach stellen.

Wartung und Pflege:

1. Reinigen Sie das Haus mit Putzlappen und Wasser.
2. Halten Sie die Schienen der Schiebetür sauber und frei von jeglichen Gegenständen, die möglicherweise eine flüssige Bewegung der Tür behindern könnten.
3. Bei Schneefall entfernen Sie regelmäßig den Schnee vom Dach.
4. Das Haus ist nicht geeignet um darin zu wohnen, sondern nur zu Lagerzwecken konzipiert.

Die deutsche Version der Anleitung ist eine genaue Übersetzung der Anleitung des Herstellers.

Die in diesem Handbuch verwendeten Bilder dienen nur zur Illustration und können nicht genau das Produkt entsprechen.



Děkujeme za nákup našeho výrobku.

Před použitím si prosím přečtete tento návod.

Montážní návod:

Dříve, než začnete s montáží, pečlivě si prostudujte všechny pokyny a informace. Domek musí být řádně ukotven k základové desce, aby nedošlo při silném větru k jeho poškození nebo zničení. Základna není součástí balení, je nutné si ji vybudovat samostatně.

Zkontrolujte, zda máte všechny potřebné díly pro stavbu domku.

Dbejte na svoji bezpečnost.

1. Domek montujte ve 2-3 lidech.
2. Při montáži používejte ochranný oděv a rukavice, protože některé části mohou být ostré.
3. V době montáže by se po staveništi neměly pohybovat děti a domácí zvířata.
4. Nikdy nestůjte na střeše celou svou vahou.

Péče a údržba:

1. Domek čistěte za pomoci hadru a vody.
2. Uchovávejte kolejničky posuvu dveří v čistotě, odstraňte předměty, které brání jejich snadnému klouzání.
3. V případě sněžení pravidelně odklízejte ze střechy domku napadaný sníh.
4. Domek není určen pro bydlení, ale pro ukládání věcí.

Česká verze návodu je přesným překladem originálního návodu výrobce.

Fotografie použité v manuálu jsou pouze ilustrační a nemusí se přesně shodovat s výrobkem.



Ďakujeme za nákup nášho výrobku.

Pred použitím si prosím prečítajte tento návod.

Návod na montáž:

Pred montážou si pozorne prečítajte všetky pokyny a informácie. Domček musí byť riadne ukotvený k základnej doske, aby pri silnom vetre nedošlo k jeho poškodeniu alebo zničeniu. Základňa nie je súčasťou balenia, je nutné ju vybudovať samostatne.

Skontrolujte, či máte všetky potrebné diely na stavbu domčeka.

Dbajte na svoju bezpečnosť.

1. Na montáž domčeka sú potrebné 2-3 osoby.
2. Pri montáži používajte ochranný odev a rukavice, pretože niektoré časti môžu byť ostré.
3. Počas montáže by sa v pracovnom prostredí nemali pohybovať deti ani domáce zvieratá.
4. Nikdy nestojte na streche celou svojou váhou.

Starostlivosť a údržba:

1. Domček čistite pomocou handry a vody.
2. Uchovávajte koľajnice posuvu dverí čisté a odstraňujte všetky predmety, ktoré by bránili jednoduchému posuvu.
3. V prípade sneženia pravidelne zo strechy domčeka odstraňujte napadaný sneh.
4. Domček nie je určený na bývanie, ale výhradne na ukladanie vecí.

Slovenská verzia návodu je presným prekladom originálneho návodu výrobcu.

Fotografie použité v návode sú len ilustračné a nemusia sa presne zhodovať s výrobkom.



Köszönjük, hogy megvásárolta termékünket.

Használat előtt kérjük olvassa el a használati útmutatót.

Telepítési útmutató:

Telepítés előtt figyelmesen olvassa el az összes utasítást és információt. A házat szilárdan és stabilan, egy alapra kell rögzíteni, hogy az erős szélben ne mozduljon el, vagy esetleg ne menjen tönkre. Az alapot a csomag nem tartalmazza, ezt egyénileg kell biztosítani. Az összeszerelés előtt ellenőrizze, hogy megvan-e minden alkatrész.

Ügyeljen a biztonságra.

1. A ház összeszereléséhez legalább 2-3 ember kell.
2. Telepítés közben vegyen fel védőöltözetet és kesztyűt, mert néhány alkatrész éles lehet.
3. A szerelés közben ne legyenek se gyermek, se háziállat ne tartózkodjon a közelben.
4. Soha ne nehezedjen a tetőre teljes súllyal.

Ápolás és karbantartás:

1. A házat ronggyal és vízzel tisztítsa.
2. A tolóajtó síneit mindig tartsa tisztán és távolítsa el azon tárgyakat, melyek akadályozhatják a gördülést.
3. Havazás esetén mindig söpörje le a havat a tetőről.
4. A ház nem alkalmas lakhatásra, csupán eszközök tárolására.

A magyar használati utasítás a gyártótól kapott verzió pontos fordítása.

A kézikönyvben használt fényképek csak illusztrációk, nem egyeznek meg pontosan a termékkel.



Dziękujemy za zakup naszego produktu.

Przed użyciem prosimy starannie przeczytać tę instrukcję.

Instrukcja montażu:

Przed przystąpieniem do montażu należy dokładnie zapoznać się z zaleceniami i informacjami. Domek musi być prawidłowo umocowany do płyty fundamentowej, aby przy silnym wietrze nie doszło do jego uszkodzenia lub zniszczenia.

Płyta fundamentowa nie stanowi elementu wyposażenia, należy ją wykonać we własnym zakresie.

Należy sprawdzić kompletność wszystkich elementów niezbędnych do budowy domku.

Należy zadbać o własne bezpieczeństwo.

1. Domek powinien być montowany przez ekipę składającą się z 2-3 pracowników.
2. Podczas prac montażowych należy korzystać z odzieży ochronnej i rękawic dlatego, że niektóre z części mogą mieć ostre krawędzie.
3. Podczas prac montażowych na placu budowy niepożądana jest obecność dzieci i zwierząt domowych.
4. Nigdy nie należy całą swoją wagą stać na dachu domku.

Pielęgnacja i konserwacja:

1. Do czyszczenia domku używać ścierki i wody.
2. Należy dbać o utrzymanie w czystości szyn do przesuwu drzwi, usuwać przedmioty hamujące przesuwanie drzwi.
3. W razie opadów śniegu, z dachu domku należy usuwać zalegający śnieg.
4. Domek nie jest przeznaczony do zamieszkania lecz tylko do przechowywania i składowania przedmiotów.

Polska wersja językowa instrukcji jest dokładnym tłumaczeniem oryginalnej instrukcji producenta.

Zdjęcia wykorzystane w tym podręczniku są jedynie ilustracją i nie może dokładnie dopasować produkt.

Hvala vam na kupnji našeg proizvoda.

Molimo pročitajte ovaj priručnik prije upotrebe.

Upute za montažu:

Prije početka montaže pažljivo pročitajte sve upute i informacije. Kućica mora biti pravilno pričvršćena za temeljnu ploču kako bi se spriječilo oštećenje ili uništenje uslijed jakog vjetra. Podnožje nije uključeno u pakiranje, mora se zasebno izgraditi.

Provjerite imate li sve potrebne dijelove za izgradnju kuće.

Vodite računa o svojoj sigurnosti.

1. Kućicu sastavljaju 2-3 osobe.
2. Tijekom montaže nosite zaštitnu odjeću i rukavice jer neki dijelovi mogu biti oštri.
3. Djeca i kućni ljubimci ne smiju biti na gradilištu tijekom montaže.
4. Nikada ne stojte na krovu punom težinom.

Njega i održavanje:

1. Kućicu čistite krpom i vodom.
2. Klizne vodilice vrata održavajte čistima, uklonite predmete koji sprječavaju njihovo lako klizanje.
3. U slučaju snježnih padalina redovito uklanjajte snijeg s krova kuće.
4. Kućica nije namijenjena za stanovanje, već za pohranu stvari.

Hrvatska verzija priručnika točan je prijevod originalnih uputa proizvođača.

Slike korištene u ovom priručniku služe samo za ilustraciju i mogu se razlikovati od stvarnog proizvoda.

Hvala za nakup našega izdelka.

Pred uporabo preberite ta priročnik.

Navodila za montažo:

Pred začetkom montaže natančno preberite vsa navodila in informacije. Hiša mora biti pravilno pritrjena na osnovno ploščo, da preprečite poškodbe ali uničenje v močnem vetru. Podstavek ni vključen v paket, zgraditi ga je treba ločeno.

Preverite, ali imate vse potrebne dele za gradnjo hiše.

Poskrbite za svojo varnost.

1. Hišo sestavljajo 2–3 osebe.
2. Med montažo nosite zaščitna oblačila in rokavice, saj so nekateri deli lahko ostri.
3. Otroci in hišni ljubljenci med montažo ne smejo biti na gradbišču.
4. Nikoli ne stojte na strehi s polno težo.

Nega in vzdrževanje:

1. Hišo čistite s krpo in vodo.
2. Drsnice tirnice vrat vzdržujte čiste, odstranite predmete, ki preprečujejo njihovo enostavno drsenje.
3. V primeru sneženja redno odstranjujte sneg s strehe hiše.
4. Hiša ni namenjena bivanju, temveč shranjevanju stvari.

Slovenska različica navodil za uporabo je natančen prevod originalnih proizvajalčevih navodil.

Fotografije, uporabljene v navodilih, so samo ilustrativne in se morda ne ujemajo popolnoma z izdelkom.



EN Installation

DE Montage

CZ Montáž

SK Montáž

HU Összeszerelés

PL Montaż

HR Sastavljanje

SLO Montáž

EN Parts list

DE Teilleiste

CZ Seznam dílů



SK Zoznam dielov































HU Alkatrész lista

PL Wykaz części

HR Popis dijelova

SLO Seznam delov

#		mm	PCS
Ana-C1		1458	x1
Ana-C1a		1245	x1
Ana-C2		1371.5	x1
Ana-C2a		1331.5	x1
Ana-B3		2064	x2
Ana-A4		1130	x1
Ana-A5		2124	x4
Ac-A6		1900	x11
Ac-A7		1900	x1
Ana-C9		1521.5	x1
Ana-C9a		1191.5	x1
Ana-B10		2063	x2
Ana-C11		783.5	x2
Ana-C12		1521.5	x1
Ana-C12a		1191.5	x1
Ana-C13		1521.5	x1
Ana-C13a		1191.5	x1
Ana-B14		2063	x2
Ana-A16		1900	x1
Ana-A16a		1900	x1
Ana-A17		1087.5	x1
Ana-A18		2077	x4
Ana-C18		904.5	x4
Ana-C18a		1811.5	x4
Ana-C21		190	x1
Ana-A22b	223	x2	
Ana-C22	223	x4	
Ana-A22a	223	x4	
Ana-C23	1518	x2	
Ana-C23a	1188	x2	
Ana-B26	2142.5	x2	
Ana-A36	2077	x2	
Ana-C36	890	x5	
Ana-C38	890	x1	
Ana-C27	1501.5	x2	
Ana-C27a	1330	x2	
Ana-B27		x2	
Ana-C30		x1	

#		mm	PCS
Ana-C31		2142.5	x1
Ana-C33		272	x4
Ac-A29		1804	x1
Ac-A29a		1804	x1
Ana-C24		1439.5	x10
Ana-C25		1439.5	x2
Ana-C25a		1439.5	x2
Ana-C28		1399.5	x2
Ana-C28a		1399.5	x2
Ana-B28		2159.5	x2
Ana-C29		2246.5	x1
Ana-C35			x2
Ana-C35a			x2
Ab-4			x12
Ana-C37			22M
Ana-P1			x4
Ana-P2			x4
Ana-P6			x1
Ana-P7			x1
Ana-P8			x1
Ab-50			x6
Ana-54			x1
Ana-55			x1
Ana-56			x1
Ana-57			x1
Ana-58		M5x45	x3
Ana-C40			x219
Ana-C41		ST4x10	x367
Ana-A42		ST4x10	x2
Ana-A43		M4x10	x18
Ana-A44		M5x8	x4
Ana-C45		ST4x25	x17
Ana-C46		M6x12	x4
Ana-C47		ST4x16	x12
Ana-C43		M4x10	x12

EN Dimensions

DE Abmessungen

CZ Rozměry

SK Rozmery

HU Méretek

PL Wymiary

HR Dimenzije

SL Dimenzije

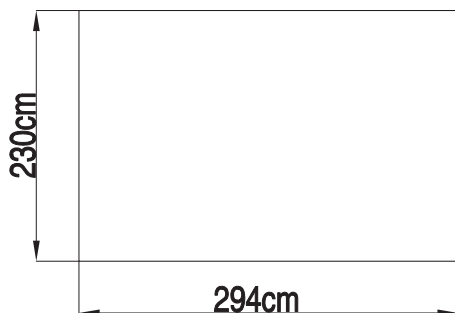
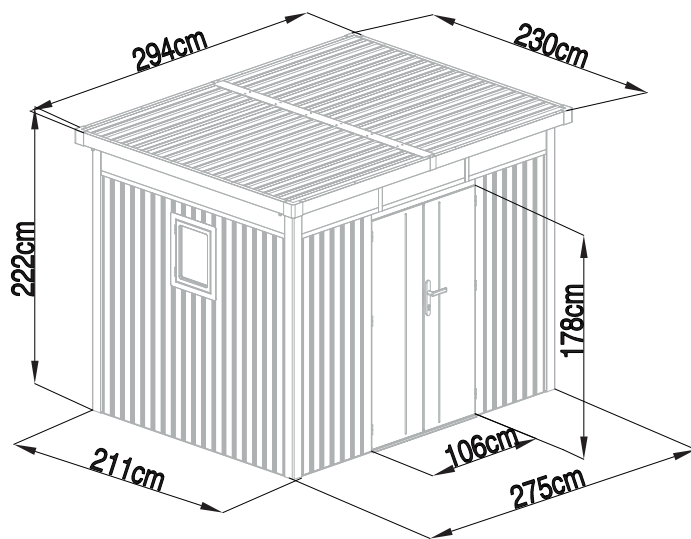

EN Tools you will need

CZ Nástroje, které budete potřebovat

HU Szükséges eszközök és szerszámok

HR Alati koji će vam trebati

DE Werkzeuge, die Sie brauchen

SK Nástroje, ktoré budete potrebovať

PL Przyrządy i narzędzia, które będą potrzebne

SL Orodja, ki jih boste potrebovali

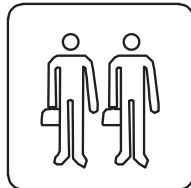
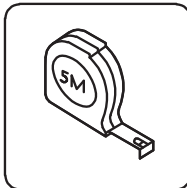
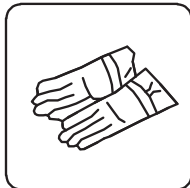
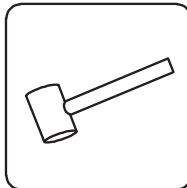
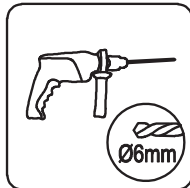
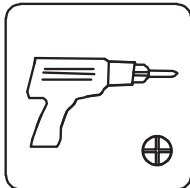

EN Assembly instructions

DE Montageanleitung

CZ Návod k montáži

SK Návod k montáži

HU Szerelési útmutató

PL Instrukcja montażu

HR Upute za montažu

SLO Navodila za namestitev

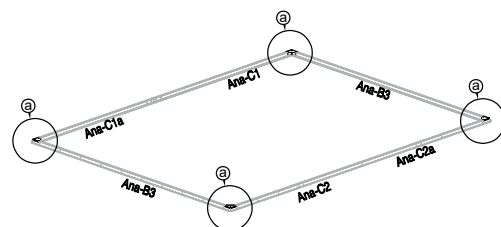
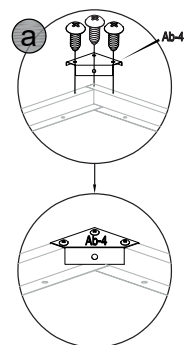
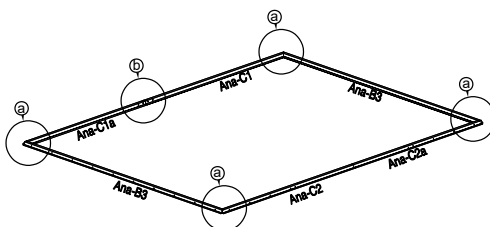
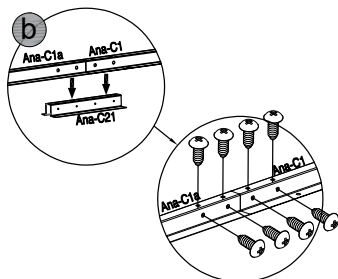
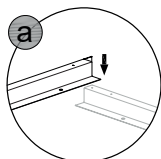

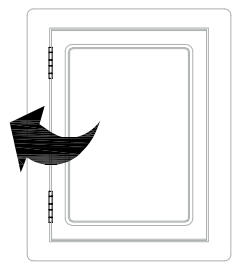



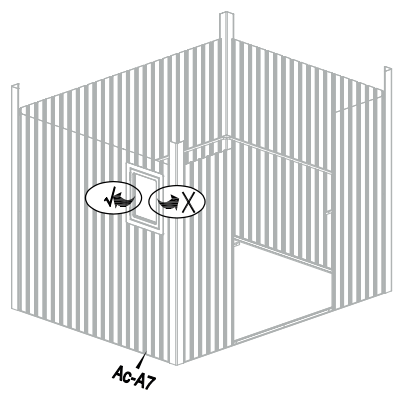
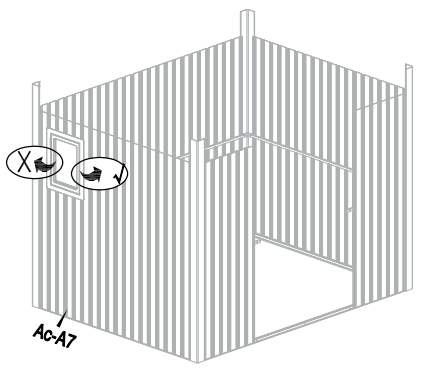
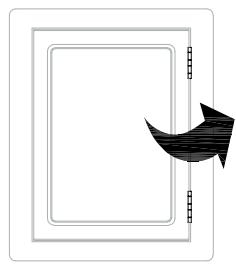

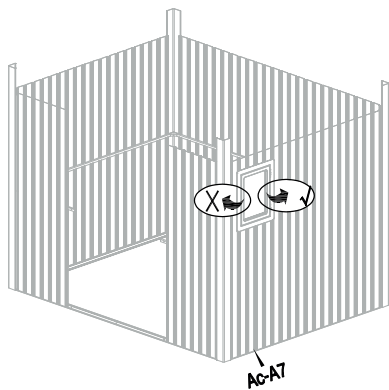
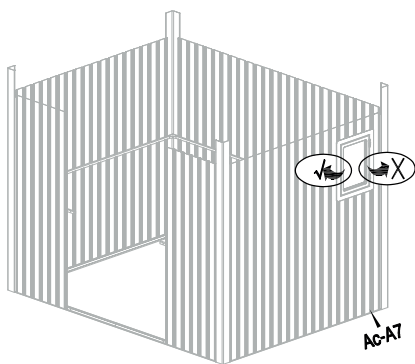
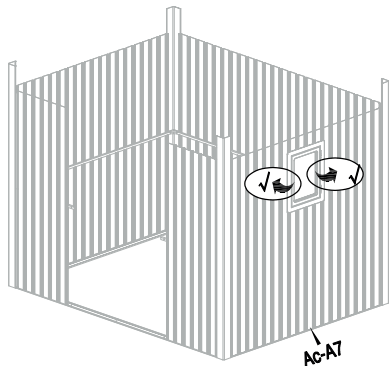
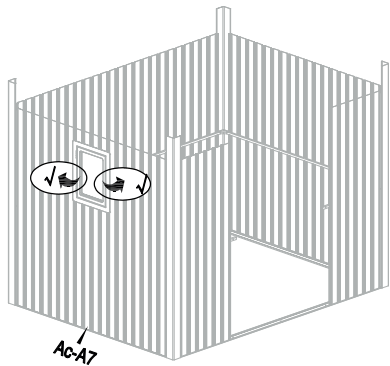

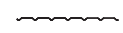
Or



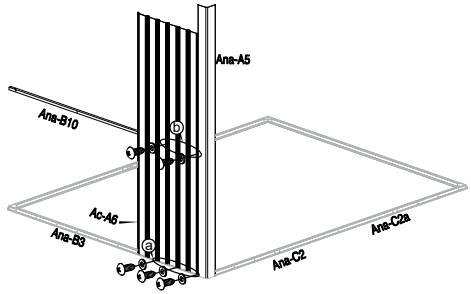
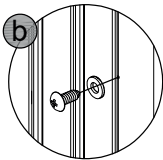
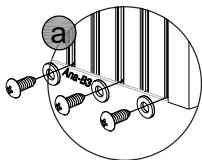
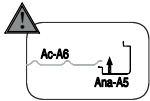

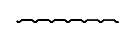

3	 Ac-A6 x1	 Ana-A5 x1	 Ana-B10 x1	 Ana-C41 x5	 Ana-C40 x5	
----------	---	--	---	---	---	--



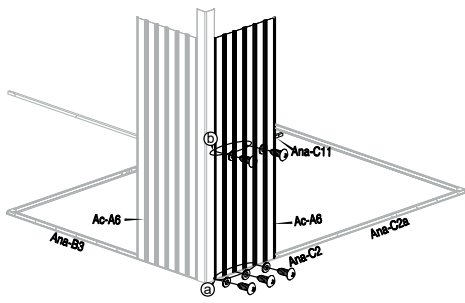
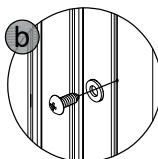
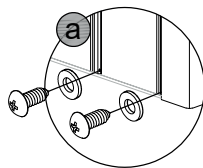



4	 Ac-A6 x1	 Ana-C11 x1	 Ana-C41 x5	 Ana-C40 x5	
----------	---	---	---	---	--

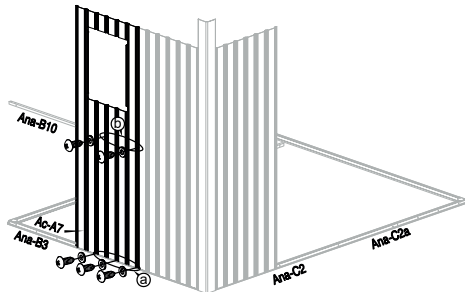
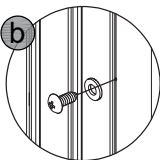
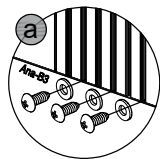





5	 Ac-A7 x1	 Ana-C41 x5	 Ana-C40 x5	
----------	---	---	---	--

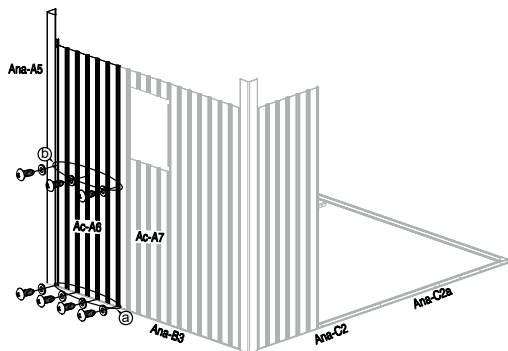
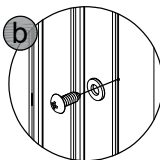
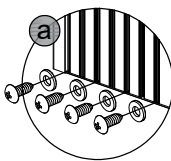





6	 Ac-A6 x1	 Ana-A5 x1	 Ana-C41 x7	 Ana-C40 x7	
----------	---	--	---	---	--

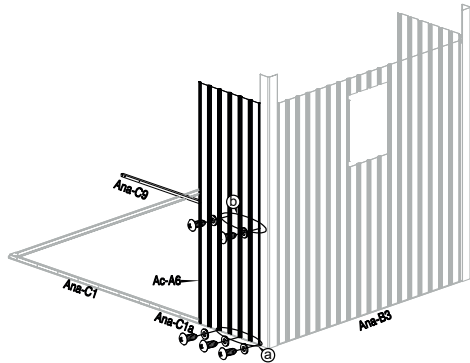
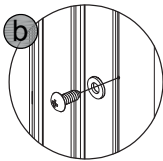
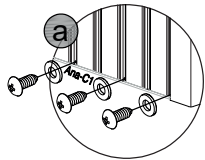

7	 Ac-A6 x1	 Ana-C9 x1	 Ana-C41 x5	 Ana-C40 x5	
----------	---	--	---	---	--





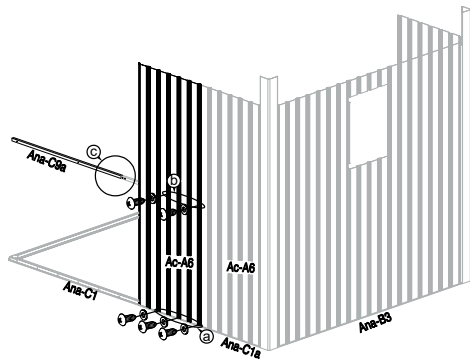
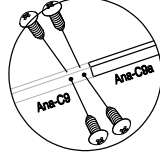
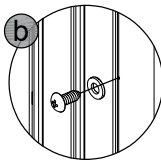
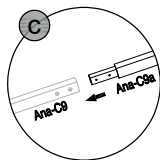
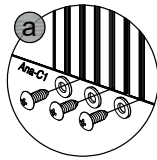

8	 Ac-A6 x1	 Ana-C9a x1	 Ana-C41 x9	 Ana-C40 x5	
----------	---	---	---	---	--

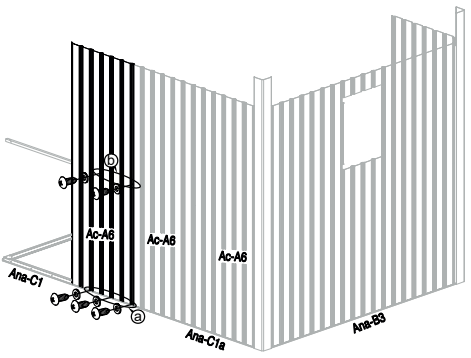
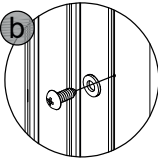
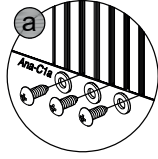





9	 Ac-A6 x1	 Ana-C41 x5	 Ana-C40 x5	
----------	---	---	---	--

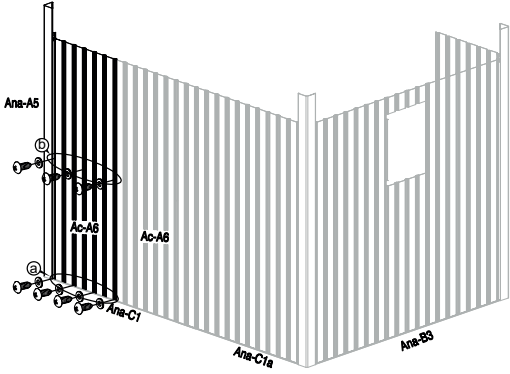
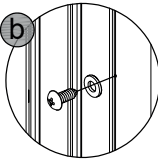
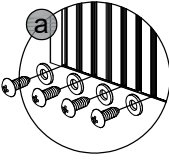

10	 Ac-A6 x1	 Ana-A5 x1	 Ana-C41 x7	 Ana-C40 x7	
-----------	---	--	---	---	--





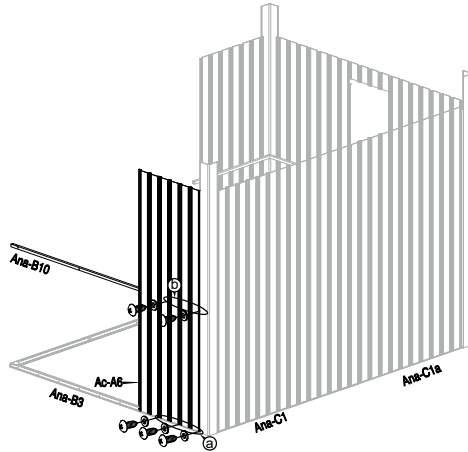
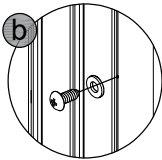
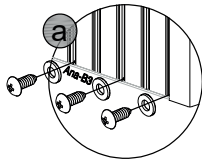

11	 Ac-A6 x1	 Ana-B10 x1	 Ana-C41 x5	 Ana-C40 x5	
----	---	---	---	---	--

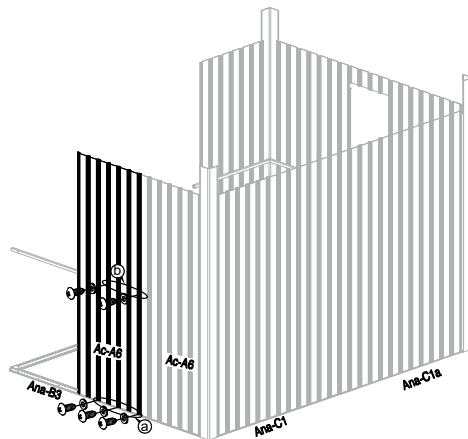
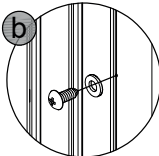
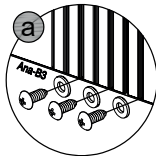





12	 Ac-A6 x1	 Ana-C41 x5	 Ana-C40 x5	
----	---	---	---	--

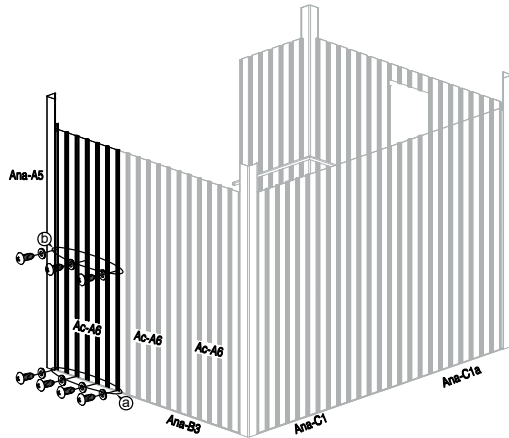
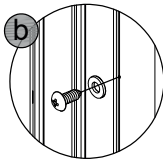
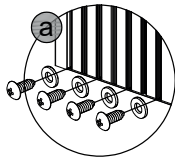

13	 Ac-A6 x1	 Ana-A5 x1	 Ana-C41 x7	 Ana-C40 x7	
-----------	---	--	---	---	--



14	 Ac-A6 x1	 Ana-C11 x1	 Ana-C41 x5	 Ana-C40 x5	
-----------	---	---	---	---	--

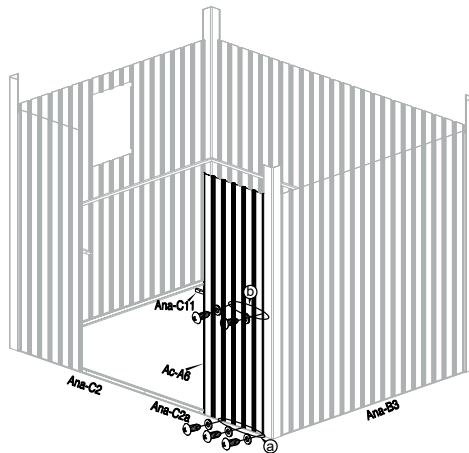
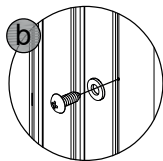
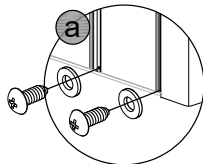



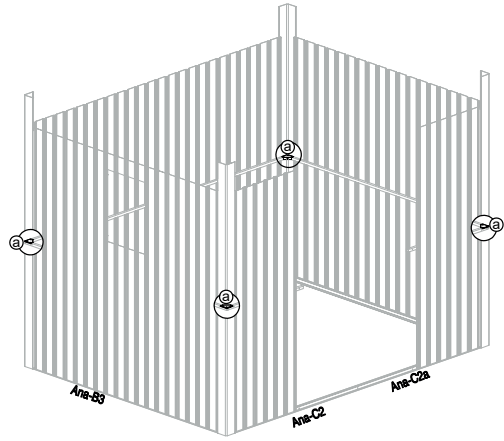
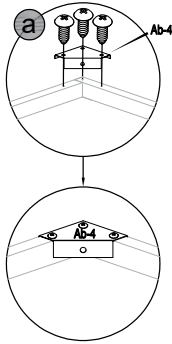

<p>15</p>	 <p>Ab-4 x4</p>	 <p>Ana-C41 x12</p>	
-----------	--	--	--

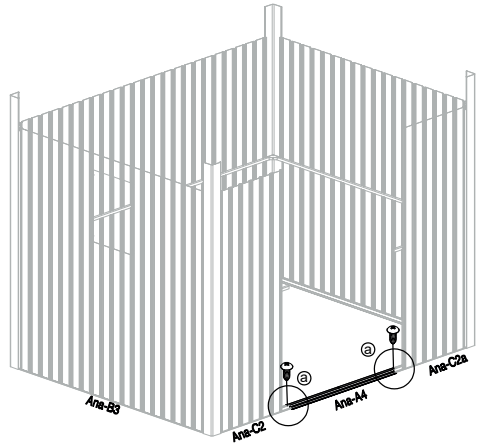
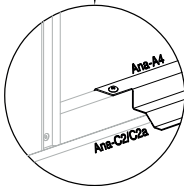
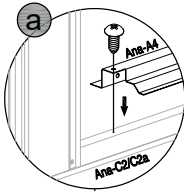
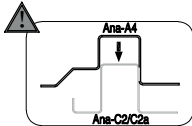

<p>16</p>	 <p>Ana-M4 x1</p>	 <p>Ana-C41 x2</p>	
-----------	--	---	--





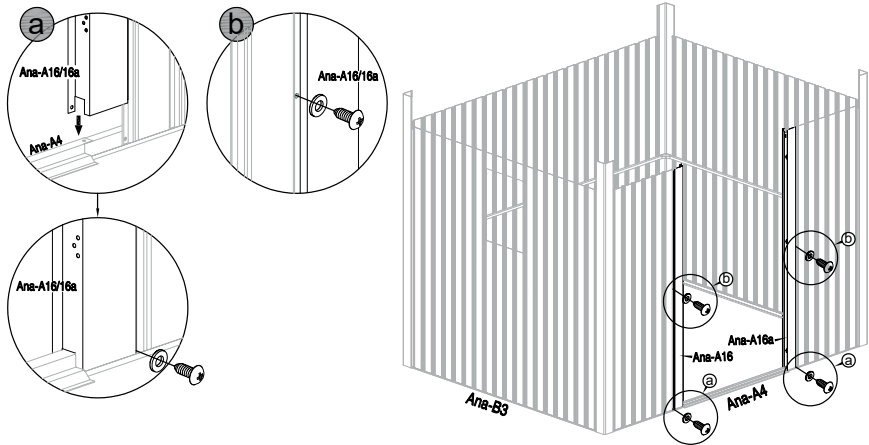

17	 Ana-A16 x1	 Ana-A16a x1	 Ana-C41 x4	 Ana-C40 x4	
----	---	--	---	---	--

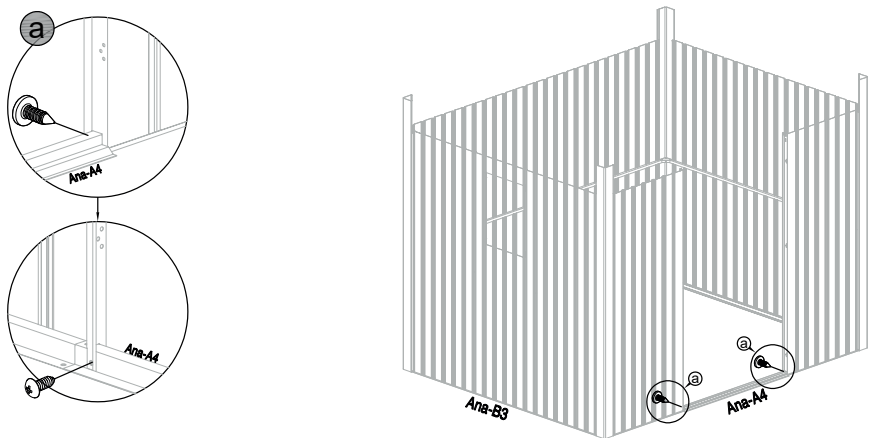





18	 Ana-C41 x2	
----	---	--

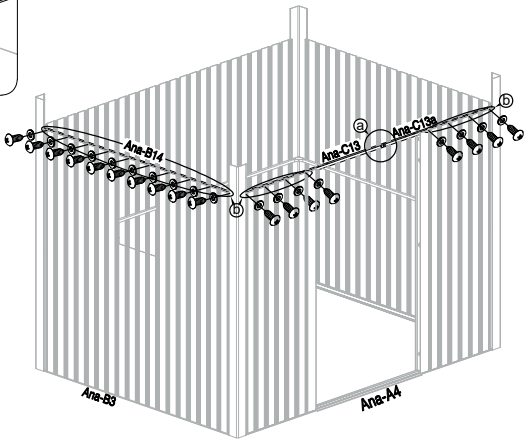
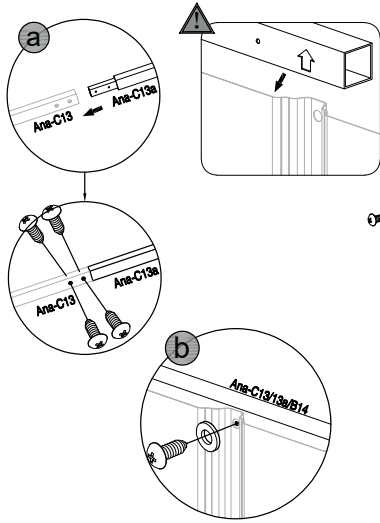

19	 Ana-B14 x1	 Ana-C13 x1	 Ana-C13a x1	 Ana-C41 x22	 Ana-C40 x18
----	---	---	--	--	--



20	 Ana-B14 x1	 Ana-C12 x1	 Ana-C12a x1	 Ana-C41 x28	 Ana-C40 x28
----	---	---	--	--	--

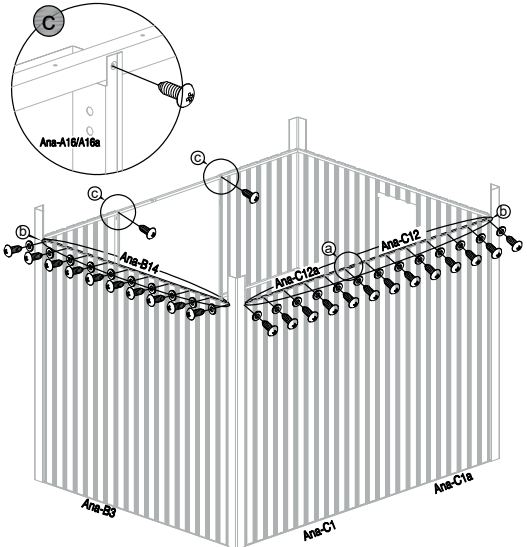
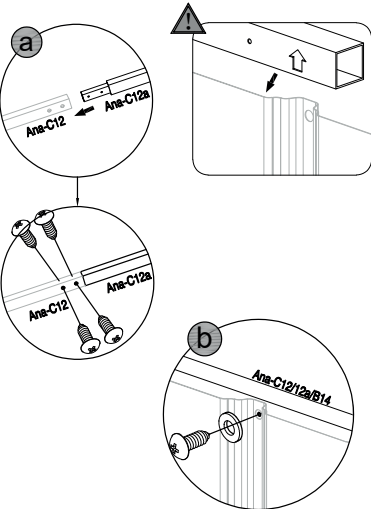

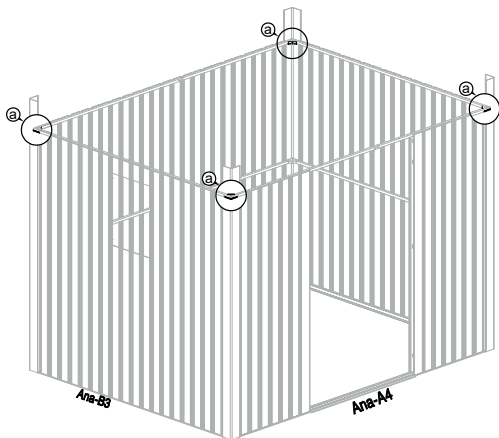
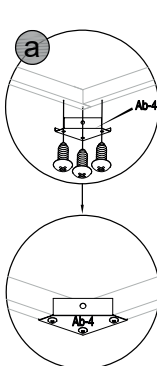

21	 Ab-4 x4	 Ana-C41 x12	
-----------	---	---	--



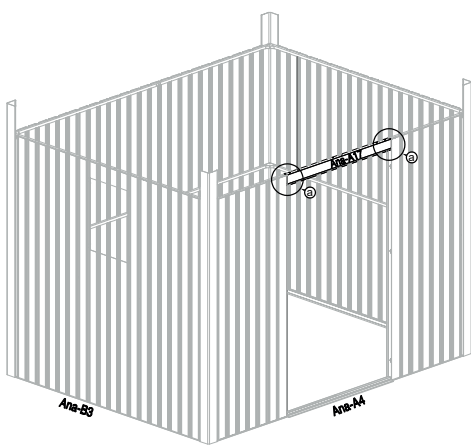
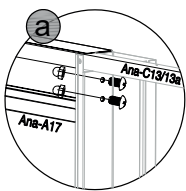
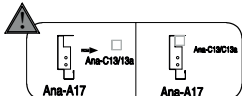



22	 Ana-A17 x1	 Ana-A44 x4	
-----------	--	--	--

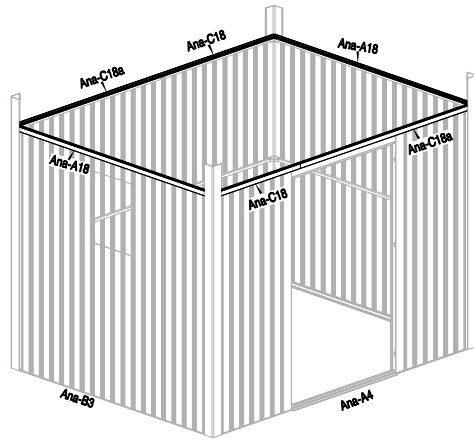
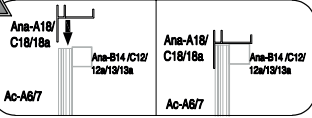



23	 Ana-A18 x2	 Ana-C18 x2	 Ana-C18a x2	
-----------	---	---	--	--

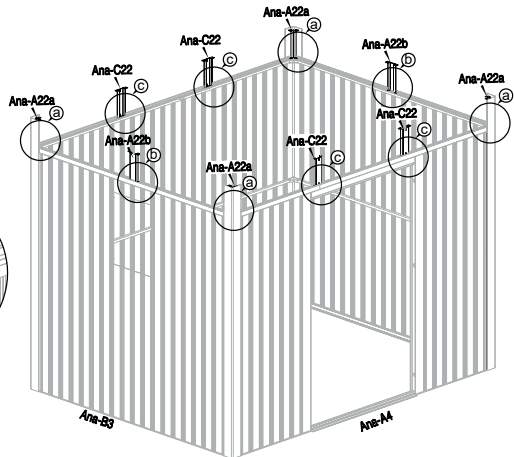
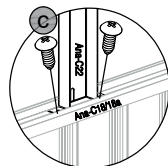
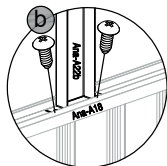
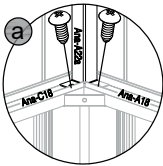

24	 Ana-A22b x2	 Ana-A22a x4	 Ana-C22 x4	 Ana-C41 x20
-----------	--	--	---	--



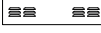

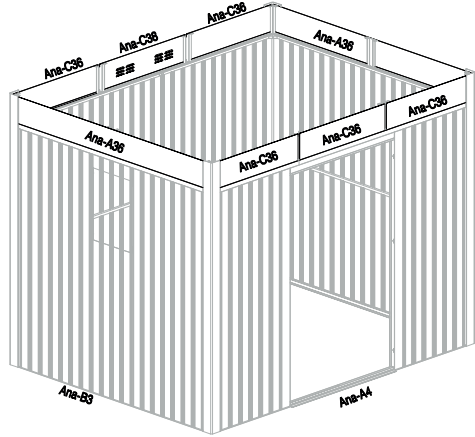
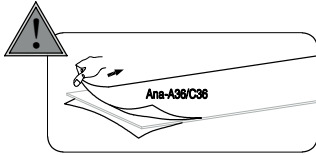

25	 Ana-A36 x2	 Ana-C36 x5	 Ana-C36 x1	
-----------	---	---	---	--

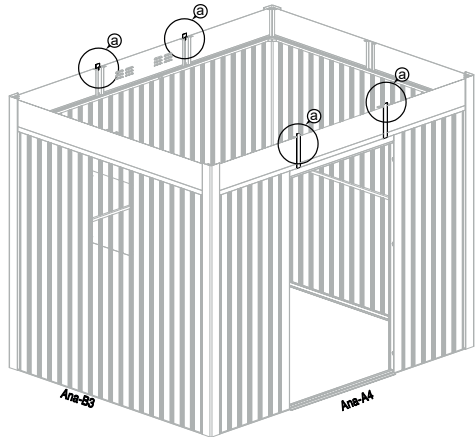
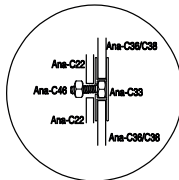
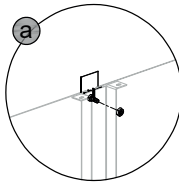
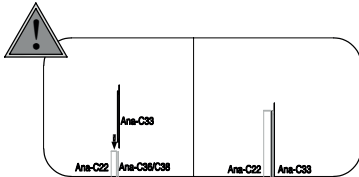



26	 Ana-C33 x4	 Ana-C46 x4	
-----------	---	---	--

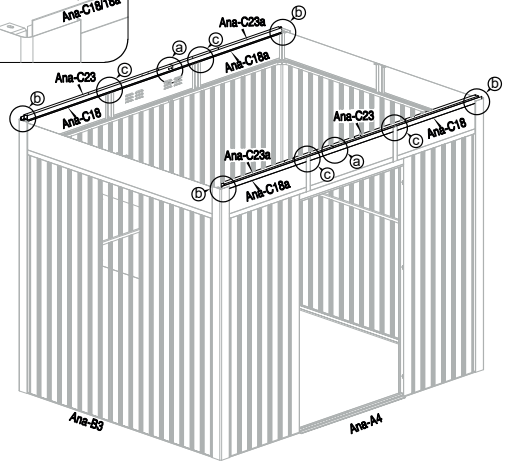
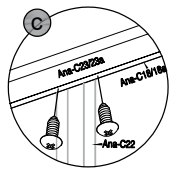
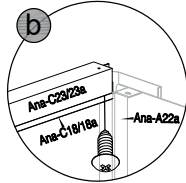
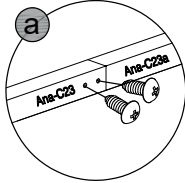

27	 Ana-C23 x2	 Ana-C23a x2	 Ana-C18 x2	 Ana-C18a x2	 Ana-C41 x16
-----------	---	--	---	--	--



28	 Ana-B27 x2	 Ana-A18 x2	 Ana-C41 x8	
-----------	---	---	---	--

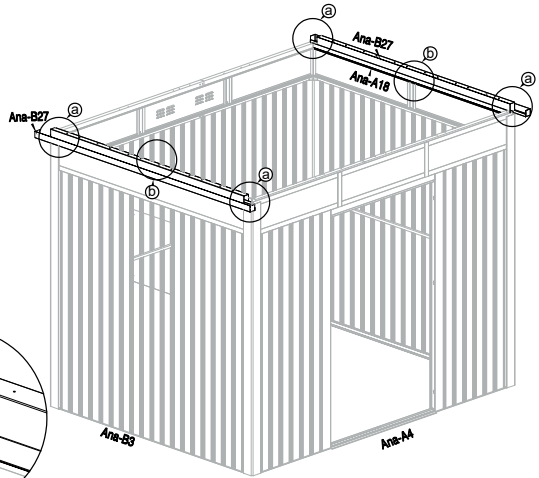
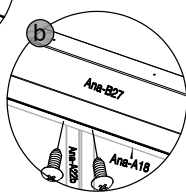
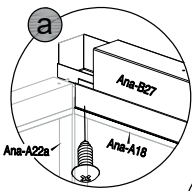
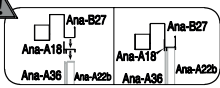

29

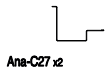

Ana-C27 x2

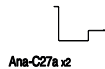

Ana-C27a x2



Ana-C41 x8

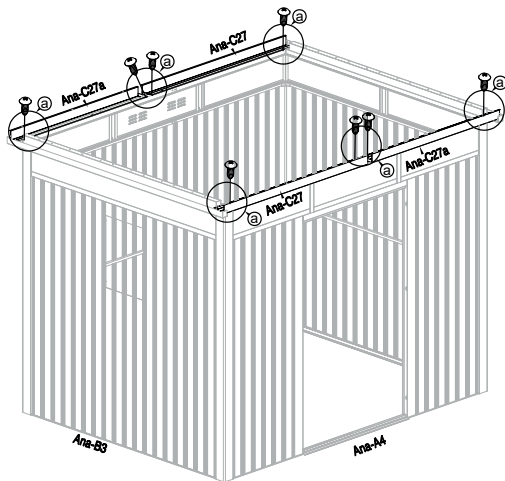
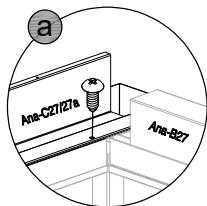

30

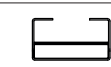

Ana-C30 x1

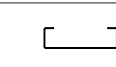

Ana-C31 x1



Ana-C43 x4

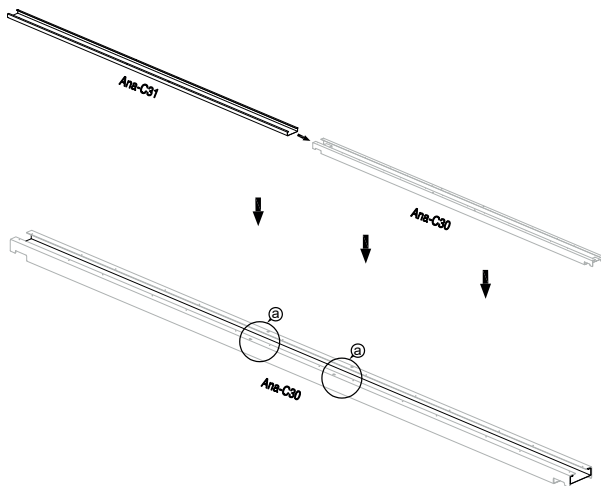
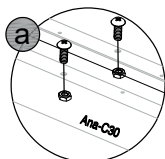



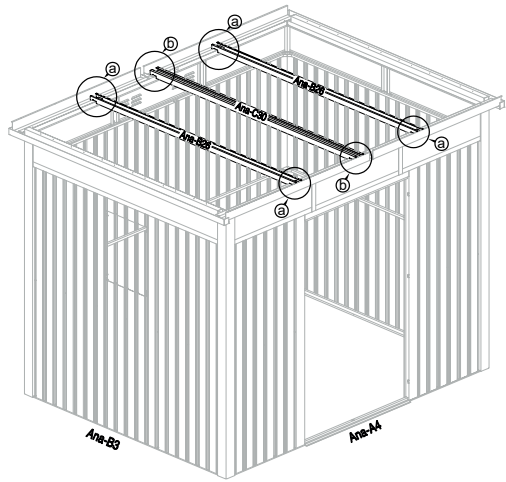
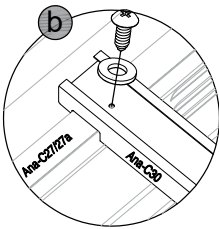
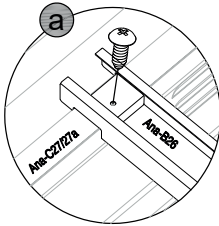

31	 Ana-B26 z2	 Ana-C41 x6	 Ana-C40 z2	
-----------	---	---	---	--

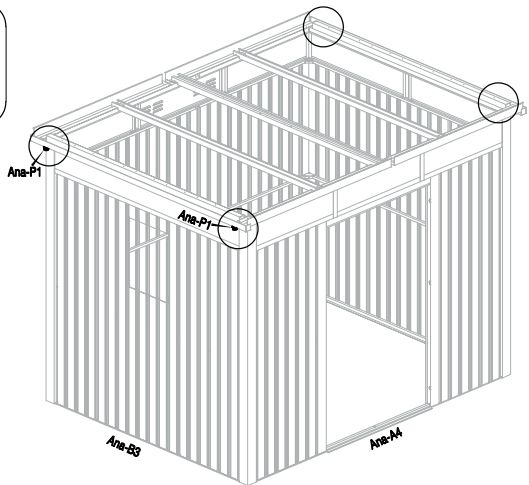



32	 Ana-P1 x4	
-----------	--	--



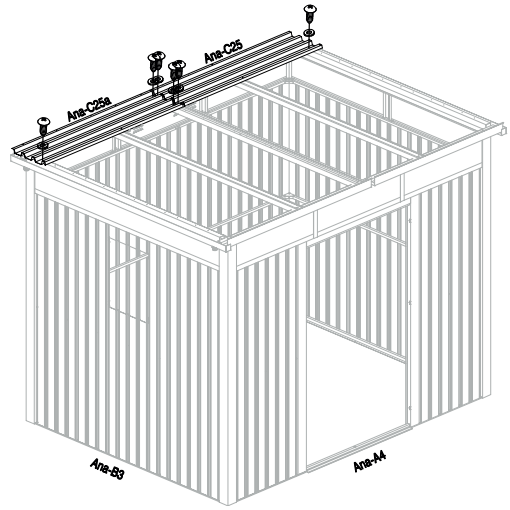
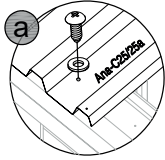



33	 <p>Ana-C25 x1</p>	 <p>Ana-C25a x1</p>	 <p>Ana-C41 x8</p>	 <p>Ana-C40 x8</p>	
----	---	--	---	---	--

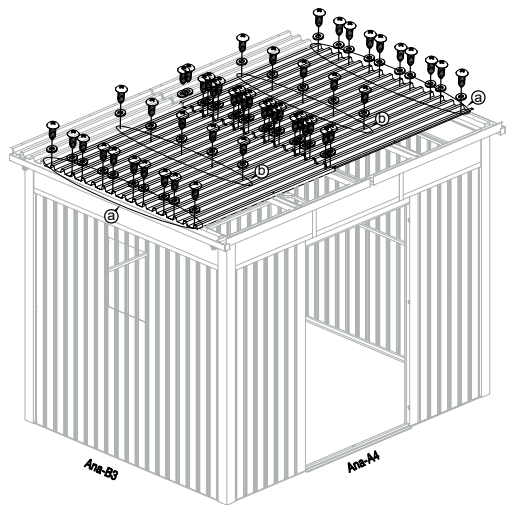
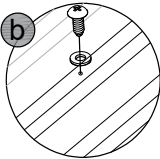
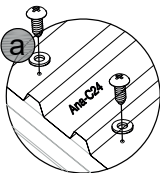

34	 <p>Ana-C24 x10</p>	 <p>Ana-C41 x50</p>	 <p>Ana-C40 x50</p>	
----	--	--	--	--





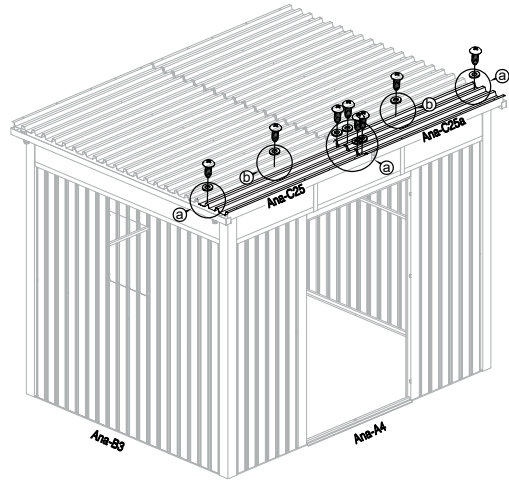
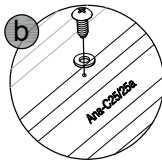
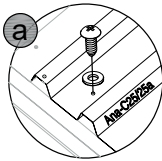
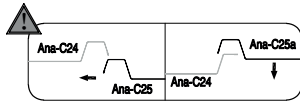



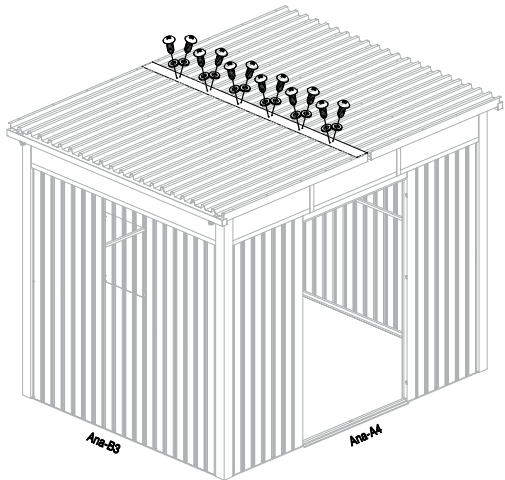
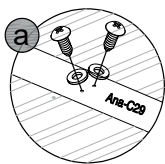

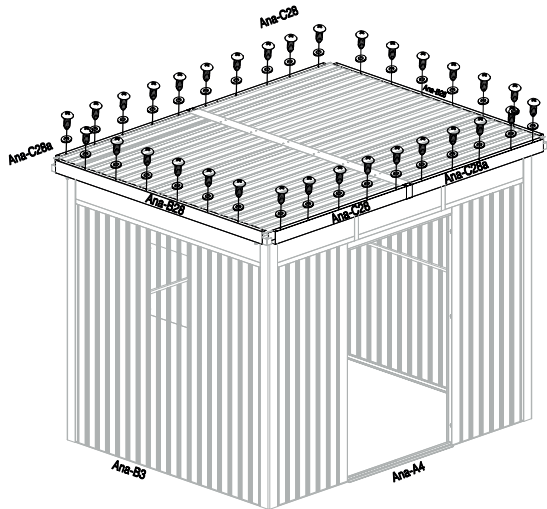
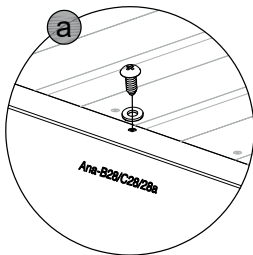
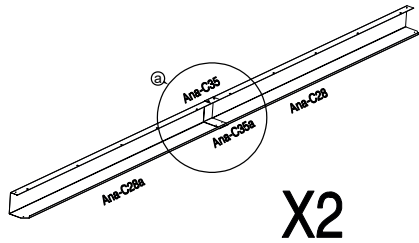
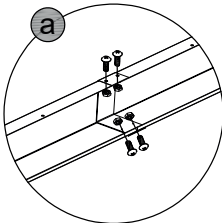
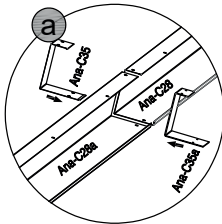
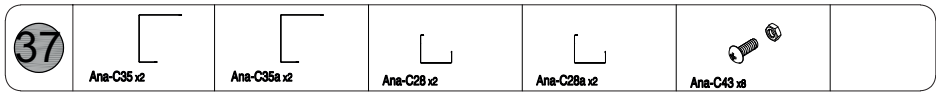
35	 Ana-C25 x1	 Ana-C25a x1	 Ana-C41 x8	 Ana-C40 x8	
-----------	---	--	---	---	--



36	 Ana-C29 x1	 Ana-C47 x12	 Ana-C40 x12		
-----------	---	--	--	--	--





41	 Ac-A29 x1	 Ac-A29a x1	 Ana-54 x1	 Ana-55 x1	 Ana-56 x1	 Ana-57 x1	 Ana-58 x2
-----------	--	---	--	--	--	--	--

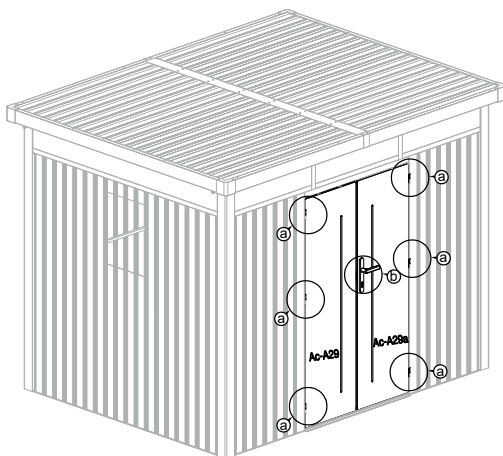
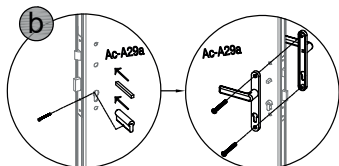
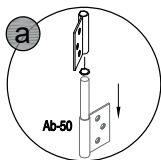

42	 Ana-P6 x1	 Ana-C41 x1
-----------	--	---

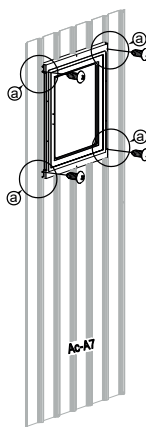
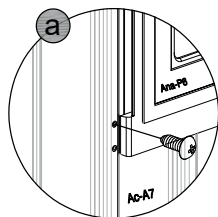
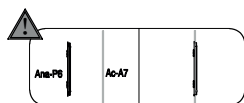

43	 Ana-P7 x1	 Ana-C41 x10	
-----------	--	--	--

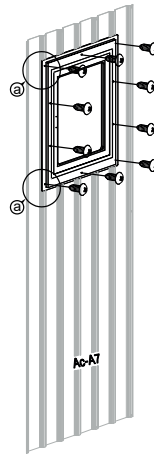
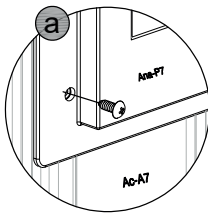
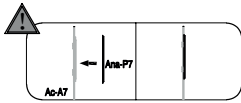

44	 Ana-P8 x1	 Ana-A42 x2	
-----------	--	---	--

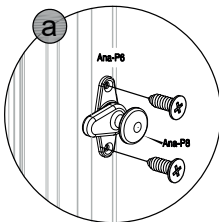

45

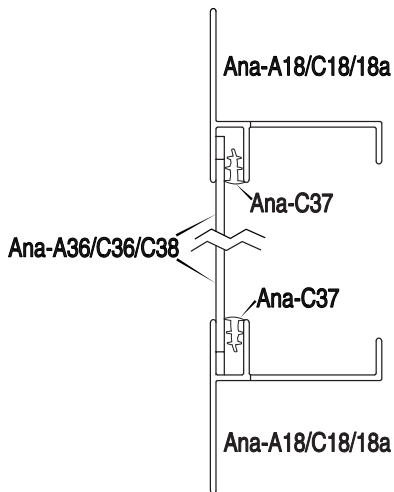

46

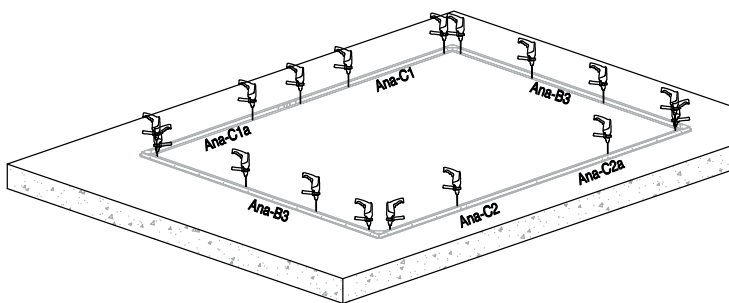
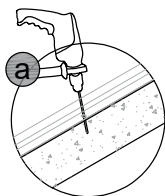
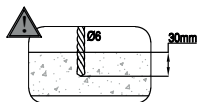

47

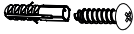

Ana-C45 x17

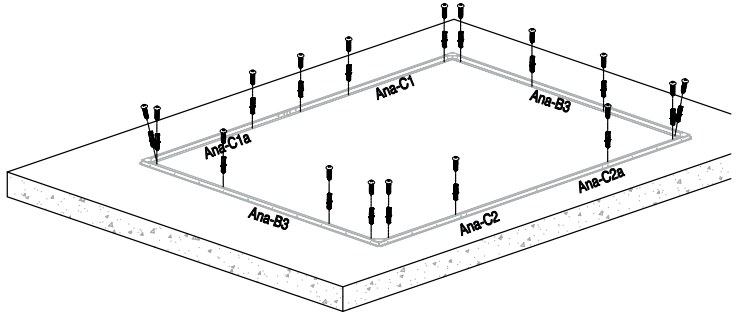
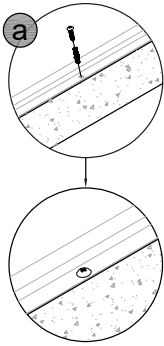

۲۷

